

HOOD SHOCKS FOR FIBERGLASS HOOD Installation

TOOLS & SUPPLIES NEEDED

Drill motor	5/16" drill bit
Center punch	Wrenches
Pencil	C clamps (6-8)
Lacquer thinner	Clean rags
Isopropyl alcohol (rubbing alcohol)	

PROCEDURE

1. Install ball stud and nut on each fender bracket in the center hole with the ball stud to the outside. See Figure 1.

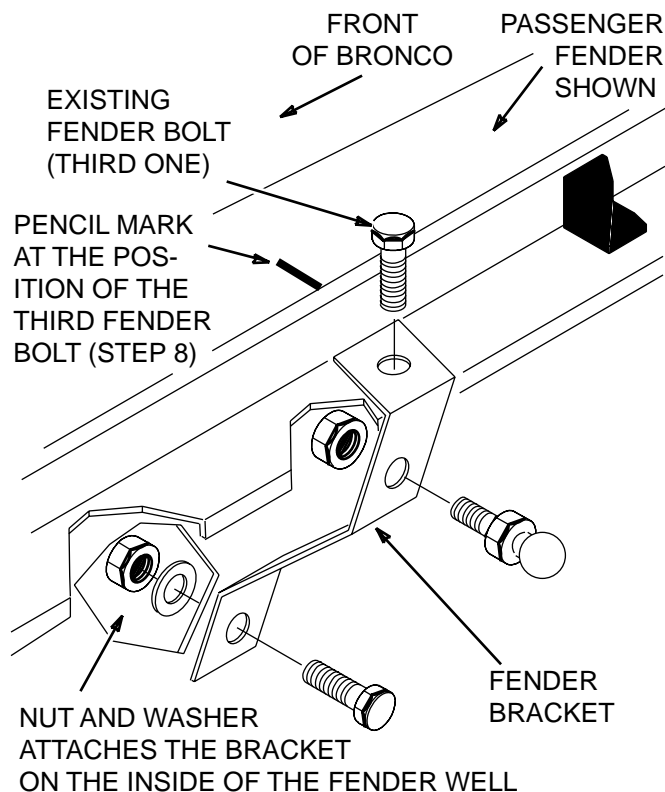

Figure 1

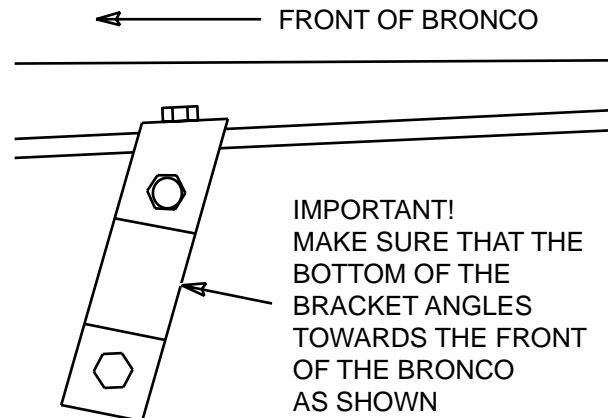

Figure 2

2. With the hood open and supported, remove the third fender bolt from the firewall on each side.
3. Position the large (fender) bracket over the fender mounting hole and secure it finger tight with one of the bolts removed in step 2, making sure the lower leg of the bracket angles towards the front of the Bronco. See Figure 2.
4. Hold lower leg of bracket against the inner fender well wall and mark it with the center punch. Drill a 5/16" hole thru the fender well.
NOTE: you may have to reposition wire loom on one or both sides.
5. Install the 1/4"x20x3/4" bolt thru the bracket and secure it with the washer and nut from the inside (tire) of the fender well. Tighten fender bolt and bracket hardware. See Figure 2.
6. Repeat steps 3 thru 5 on the opposite fender.

7. Install a ball stud and nut onto each hood bracket/stiffener as shown in Figure 3.

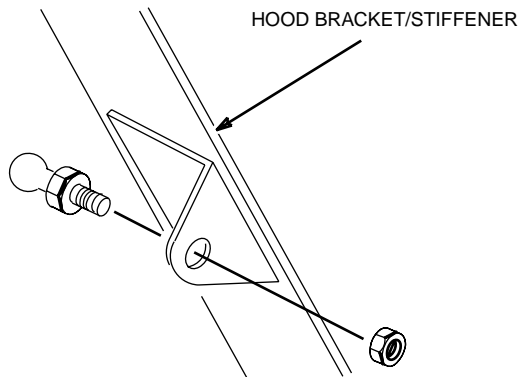

Figure 3

NOTE: In the following steps, the passenger hood bracket/stiffener is installed. The driver side hood bracket/stiffener is installed in the same way.

8. With the hood opened and supported, mark the location of the third fender bolt by making a pencil mark on the fender next to the bolt. This mark should be clearly visible when the hood is closed. See Figure 1.
9. Close the hood and measure 12" from the fender bolt mark, towards the rear of the hood and make a mark on the edge of the hood. See Figure 4.

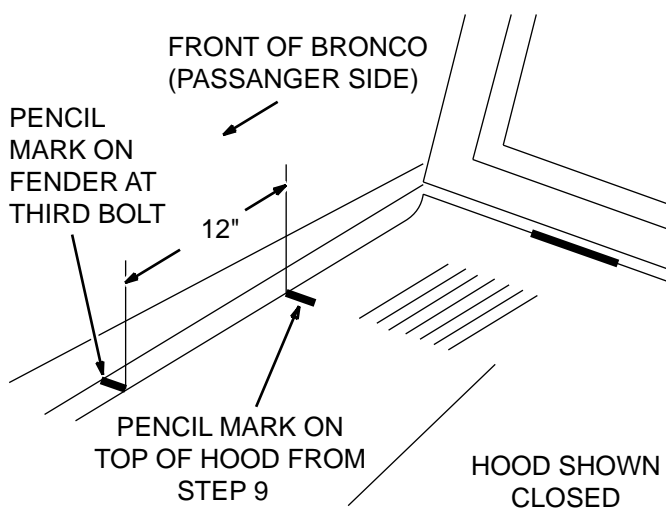

Figure 4

10. With the hood open and supported, carefully transfer the hood mark made in Step 9 to the under side of the hood. This will be the point the ball stud on the hood bracket/stiffener will be centered on. See Figure 5.

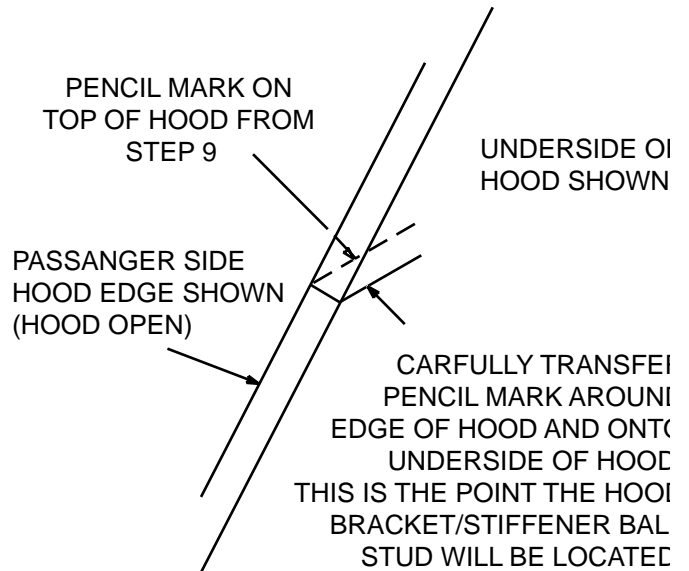

Figure 5

11. For the hood bracket/stiffener to mount properly, the hood must be very clean! Clean the entire outside edge of the hood, 3" wide, with lacquer thinner and let dry completely. Then clean the area with isopropyl alcohol and let dry completely. See Figure 6.
12. Mark the underside of the hood in four places, 1 1/4" from the outside edge of the hood. The hood bracket/stiffener will be located on these marks. See Figure 7.

NOTE: Yellow dot on the hood bracket/stiffener is passenger side. Red dot on the hood bracket/stiffener is driver side.

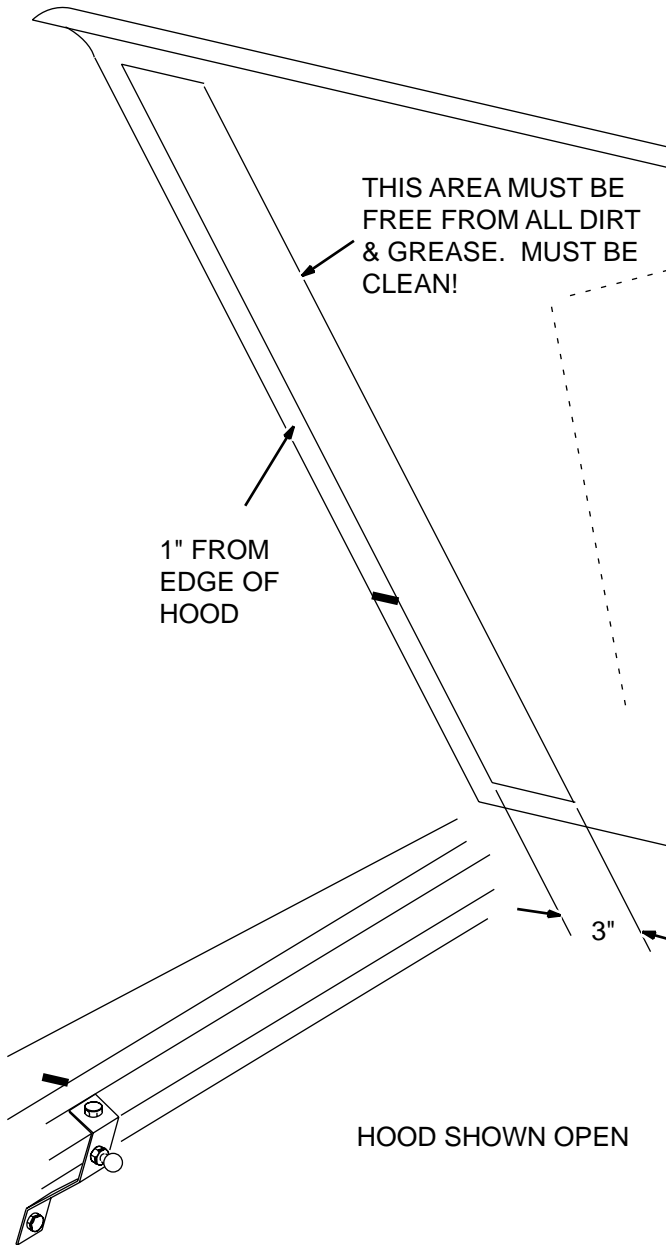

Figure 6

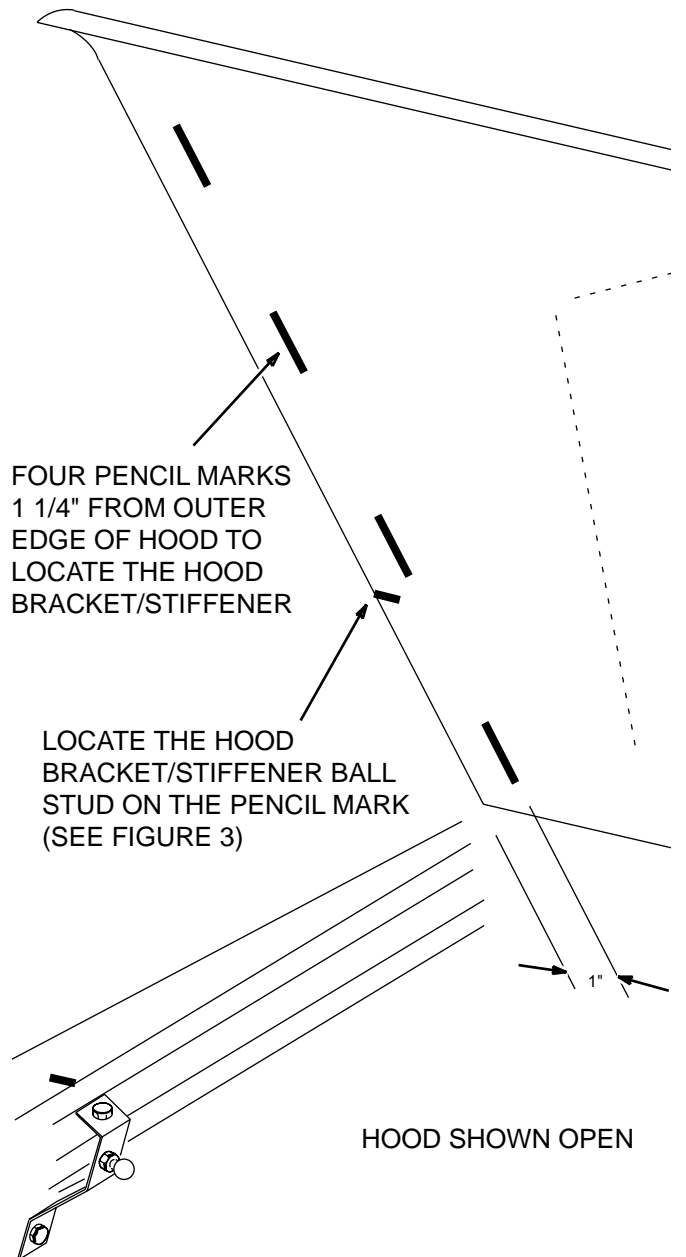

Figure 7

13. Prepare the supplied adhesive according to the instructions included inside the adhesive's packaging. Liberally apply prepared adhesive to the cleaned area where the hood bracket/stiffener will be attached (Figure 4). Locate the hood bracket/stiffener on the marks made in step 12, making sure to locate the ball stud on the mark as shown in Figure 8. Work quickly and attach the hood bracket/stiffener before the adhesive dries.
14. Secure the hood bracket/stiffener with 3 or 4 C clamps evenly spaced for 12 hours.
15. After the required drying time, snap shock body onto hood (upper) ball studs on both sides of hood.
16. Lift hood off of the support and snap shock rod to fender (lower) ball studs on both fender brackets.
17. Carefully close hood while watching for bending of the hood.

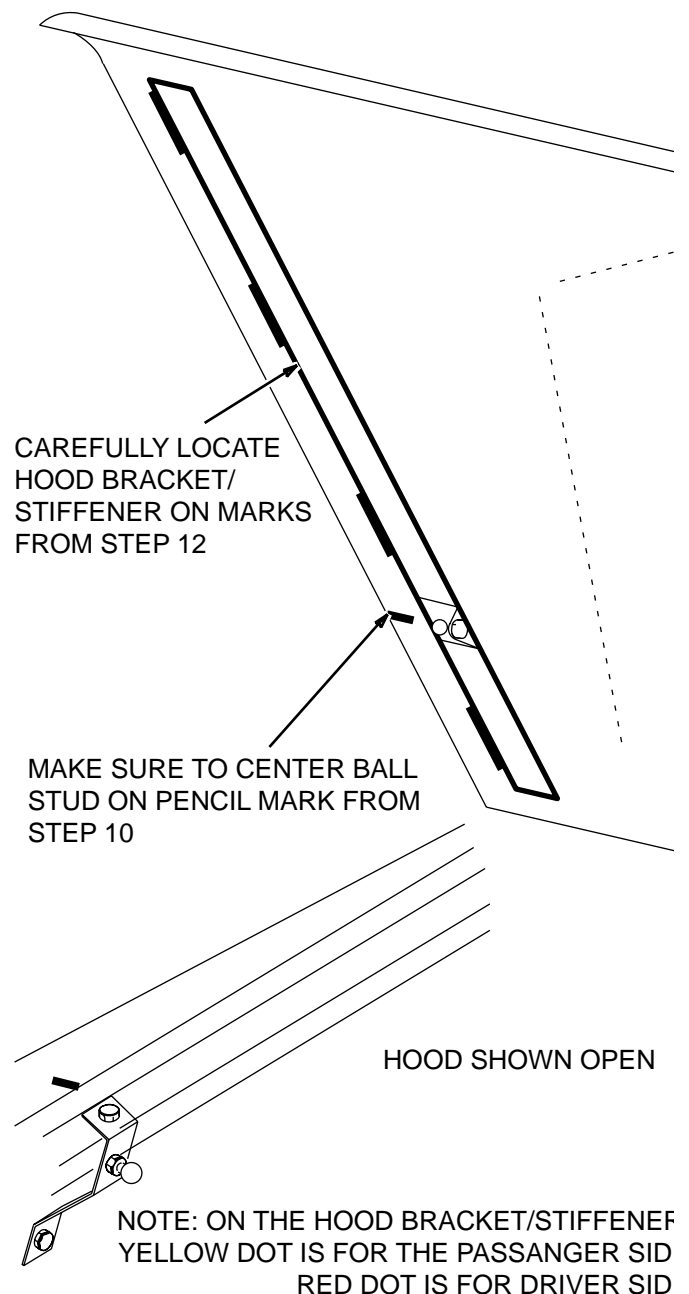

Figure 8