

# Hood Shocks

## Kit Includes:

- |     |                               |     |                           |
|-----|-------------------------------|-----|---------------------------|
| q 2 | Spring Lifts                  |     |                           |
| q 2 | Hood brackets                 | q 2 | SS Phillips head #14x1/2" |
| q 2 | Fender brackets (Pass/Driver) | q 2 | 1/4-20 Zinc nut           |
| q 4 | 5/16" Ball studs              | q 4 | 1/4" Flat washer          |
| q 4 | 5/16" Nyloc nuts              | q 2 | 1/4-20x3/4" Screw         |

INSPECTED BY: \_\_\_\_\_

## TOOLS AND SUPPLIES NEEDED:

Drill motor                    1/8" & 5/16" drill bit                    Center punch  
Wrenches                    Hammer                    Awl

OPTIONAL: short piece of fuel line or 1/2" masking tape

1. Install the ball studs and nuts on the large (fender) bracket in the center hole with the ball stud to the outside. See Figure 1.

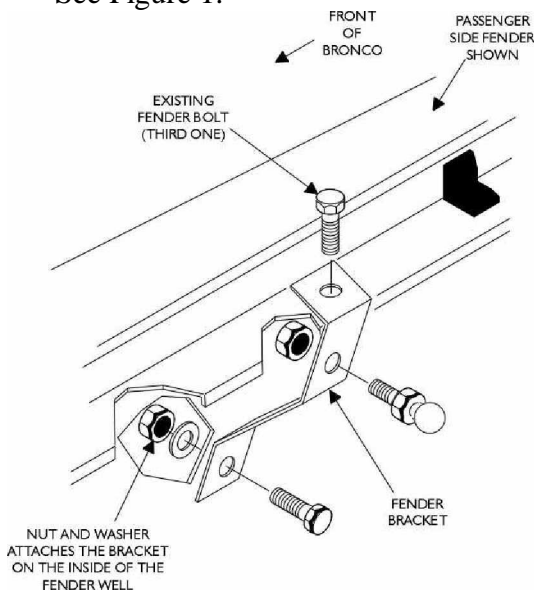

Figure 1

2. The smaller (hood) bracket will have the ball stud mounted on the inside over the two mounting holes. See Figure 2.

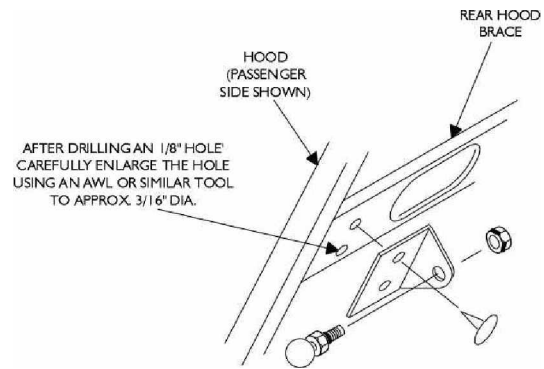

Figure 2

3. With the hood open and supported, remove the third fender bolt from the firewall on each side.
4. Position the large (fender) bracket over the fender mounting hole and secure it finger tight with one of the bolts removed in step 3, making sure the lower leg of the bracket angles towards the front of the Bronco. See Figure 3.
5. Hold lower leg of bracket against the inner fender well wall and mark it with the center punch. Drill a 5/16" hole thru the fender well.

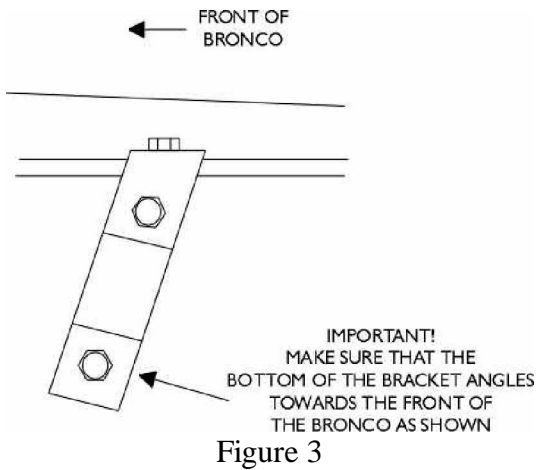
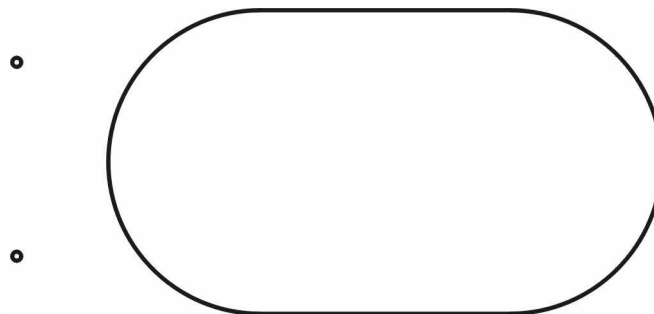

Figure 3

*NOTE: you may have to reposition wire loom on one or both sides.*

6. Install the 1/4"x20x3/4" bolt thru the bracket and secure it with the washer and nut from the inside (tire) of the fender well. Tighten fender bolt and bracket hardware. See Figure 1.
7. Repeat steps 4 thru 6 on the opposite fender.
8. Position the provided drilling template on the rear hood cross brace (closest to the firewall) and center punch the mounting holes. See Figure 2.

9. To protect the hood, slip a piece of fuel line on to the 1/8" drill and trim it so 1/8" of the drill shows or wrap 1/2" masking tape around the 1/8" drill approx. 1/8" from end of drill. Keep wrapping till you get a diameter of approx. 1/4". Both will act as a drill stop and will protect your hood from damage. Carefully drill the center punched marks.
10. Enlarger the holes to approx 3/16" using the awl or similar tool. Careful not to damage the hood.
11. Using the provided screws, install the small bracket to the hood cross member. The ball stud will be facing away from engine.
12. Repeat steps 8 thru 11 on the opposite side of hood.
13. Snap shock body onto hood (upper) ball studs on both sides of hood.
14. Lift hood off of hood prop rod and snap shock rod to fender (lower) ball studs on both fender brackets.
15. Remove the hood prop rod from the core support.
16. Carefully close hood. You will have to pull the hood down the first half of hood travel and support it the last half.



Hood Brace Bracket Drilling Template